

Specification

for

LCD Module

LH1610-1

LH1610-1 LCD MODULE

1. FEATURES

- Display Mode: STN, Positive, TRANSFLECTIVE.Y/G OR BLUE
- Display Formate: 16 Character x 1 Line
- Viewing Direction: 6 O'Clock
- Input Data: 4-Bits or 8-Bits interface available
- Display Font : 5 x 8 Dots
- Power Supply : Single Power Supply (5V±10%)
- Driving Scheme : 1/16Duty,1/5Bias

2. ABSOLUTE MAXIMUM

Item	Symbol	Min.	Max.	Unit
Power Supply for logic	Vdd	-0.3	+7.0	V
Power supply for LCD Drive	Vlcd	Vdd-11.5	Vdd+0.3	V
Input Voltage	Vi	-0.3	Vdd+0.3	V
Operating Temperature	Ta	0	+50	°C
Storage Temperature	Tstg	-10	+60	°C

3. ELECTRICAL CHARACTERISTICS

(Ta=25°C;Vdd=3.0V±10%,otherwise specified)

Item	Symbol	Test Condition	Min.	Typ.	Max.	Unit
Power Supply for Logic	Vdd	--	4.7	5.0	5.5	V
Operating Voltage for LCD	Vdd-Vo	--	--	5.0	--	V
Input High voltage	Vih	--	2.2	--	Vdd	V
Input Low voltage	Vil	--	-0.3	--	0.6	V
Output High voltage	Voh	-Ioh=0.2mA	2.4	--	--	V
Output Low voltage	Vol	Iol=1.2mA	--	--	0.4	V
Power supply current	Idd	Vdd=3.0v	--	1.1	--	mA

4. MECHANICAL PARAMETERS

Item	Description	Unit
PCB Dimension	80.0X36.0	mm
View Dimensio		

5. PIN ASSIGNMENT

No.	Symbol	Level	Function	
1	Vss	--	0V	Power Supply
2	Vdd	--	+5V	
3	V0	--	for LCD	
4	RS	H/L	Register Select: H:Data Input L:Instruction Input	
5	R/W	H/L	H--Read L--Write	
6	E	H,H-L	Enable Signal	
7	DB0	H/L	Data bus used in 8 bit transfer	
8	DB1	H/L		
9	DB2	H/L		
10	DB3	H/L		
11	DB4	H/L	Data bus for both 4 and 8 bit transfer	
12	DB5	H/L		
13	DB6	H/L		
14	DB7	H/L		
15	BLA	--	BLACKLIGHT +	
16	BLK	--	BLACKLIGHT -	

6. SYSTEM BLOCK DIAGRAM

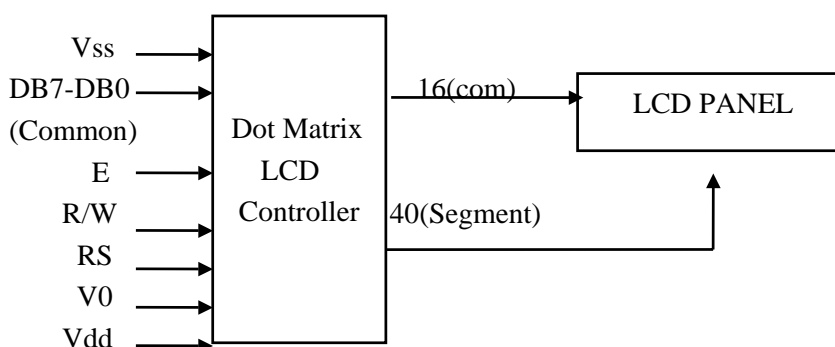

7. AC characteristics (Vdd=5V±10%,Vss=0V Ta=25°C)

(1)Write mode(writing data from Micom to KS0070B)

Characteristic	Symbol	Min.	Tvp.	Max.	Unit	Test pin
E cycle time	t_c	500	--	--	ns	E
E rise time	t_r	--	--	25	ns	E
E fall time	t_f	--	--	25	ns	E
E pulse width (High,Low)	t_w	220	--	--	ns	E
R/W and RS set-up time	t_{su1}	40	--	--	ns	R/W,RS
R/w and RS hold time	t_{h1}	10	--	--	ns	R/W,RS
Data set-up time	t_{su2}	60	--	--	ns	DB0~DB7
Data hold time	t_{h2}	10	--	--	ns	DB0~DB7

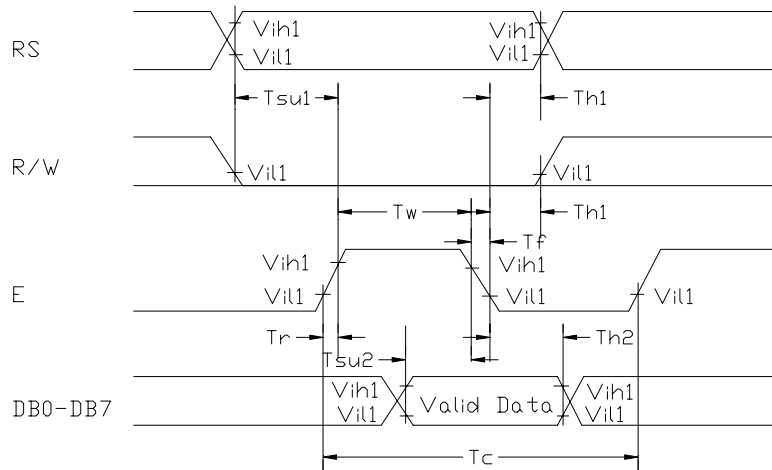

(2) Read mode(Reading data from KS0066 to Micom)

Characteristic	Symbol	Min.	Typ.	Max.	Unit	Test pin
E cycle time	t_c	500	--	--	ns	E
E rise time	t_r	--	--	25	ns	E
E fall time	t_f	--	--	25	ns	E
E pulse width (High,Low)	t_w	220	--	--	ns	E
R/W and RS set-up time	t_{su1}	40	--	--	ns	R/W,RS
R/w and RS hold time	t_{h1}	10	--	--	ns	R/W,RS
Data set-up time	t_{su2}	--	--	120	ns	DB0~DB7
Data hold time	t_{h2}	20	--	--	ns	DB0~DB7

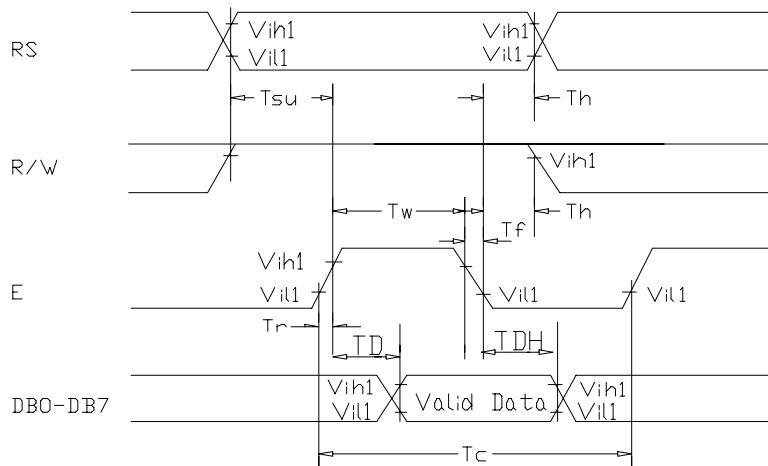

Display Clear	L	L	L	L	L	L	L	L	L	L	H
Return Home	L	L	L	L	L	L	L	L	L	H	X
Entry Mode Set	L	L	L	L	L	L	L	H	I/D	SH	I/D:set cursor move direction H-Increase L-Decrease SH:Specifies shift of display H-display is shifted L-Display is not shifted
Display On/Off	L	L	L	L	L	L	H	D	C	B	D:Display(H-on,L-off) C:Cursor(H-on,L-off) B:Blinking(H-on,L-off)
Shift	L	L	L	L	L	H	S/C	R/L	X	X	SC:(H-Display shift,L-Cursir move) R/L:(H-Right shift,L-Left shift)
Set Function	L	L	L	L	H	DL	N	F	X	X	DL:(H-8 bits interface,L-4 bits interface) N:(H-2 line display,L-1 line display) F:(H-5 x 10 dots,L-5 x 7 dots)
Set CG RAM Address	L	L	L	H	CG RAM address (corresponds to address)					CG RAM Data is sent and received after this setting	
Set DD RAM Address	L	L	H	DD RAM address					DD RAM Data is sent and received after this setting		
Read Busy Flag & Address	L	H	BF	Address Counter used for Both DD & CG RAM address					BF:(H-Busy ,L-Ready) --Reads BF indication internal operating is being performed --reads address counter contents		
Write Data	H	L	Write Data					Write data into DD or CG RAM			
Read Data	H	H	Read Data					Read data from DD or CGRAM			

■ ASSEMBLY DIAGRAM

