Specification

For

LCD Module

LH12232-2

■PHYSICAL DATA

Item	Contents	Unit
LCD type	STN	--
LCD duty	1/32	--
LCD bias	1/5	--
Viewing direction	6	o'clock
Number of dots	122×32	Dots
Dot size(W×H)	0.36×0.41	Mm
Dot pitch(W×H)	0.40×0.45	mm

■ABSOLUTE MAXIMUM

Item	Symbol	Standard value	Unit
Power Supply Voltage	Vdd	0 ~ +5.0	V
Power supply for LCD Drive	Vlcd	- ~ 5	V
Input Voltage	Vin	-0.3 ~ Vdd+0.3	V
Operating Temperature	Top	-20 ~ +70	°C
Storage Temperature	Tstg	-30 ~ +80	°C

■MECHANICAL PARAMETERS

Item	Description	Unit
PCB Dimension	93.0 x 44.0x1.6	mm
Outline Dimension	93.0 x 44.0 x 13	mm
View Dimension	60.6 x 18.3	mm

■PIN ASSIGNMENT

Pin NO.	Symbol	Level	Function
1	VCC	+5V	Power supply
2	GND	0V	Power Ground
3	VLCD	--	For LCD drive voltage(variable)
4	RESET	H/L	Reset Signal
5	E1	H/L	U1 Enable Signal
6	E2	H/L	U2 Enable Signal
7	R/W	H/L	H: Read Signal, L: Write Signal
8	A0	H/L	H: Display Data, L:Display Instruction
9-16	DB0~DB7	H/L	Data bus
17	SLA	H/L	LED+
18	SLB	0V	LED-

■ELECTRICAL CHARACTERISTICS

DC Characteristics (Ta=25°C; Vdd=5.0V±10%)

PARAMETER	SYMBOL	CONDITION	MIN	TYP	MAX	UNIT
Operating Voltage(1)	VDD		4.5	5.0	5.5	V
Input Voltage	High	E,R/W,RS,DB0~DB7 Terminals	0.7VDD	--	VCC	V
	Low		0	--	0.3VCC	
Operating Current	Idd	During Display	--	--	--	mA

*LCD Module 内自带负压 (-5V DC)

AC characteristics (Vdd=5V±10%, Vss=0V Ta=25°C)

• MPU Bus Read/Write i (80-family MPU)

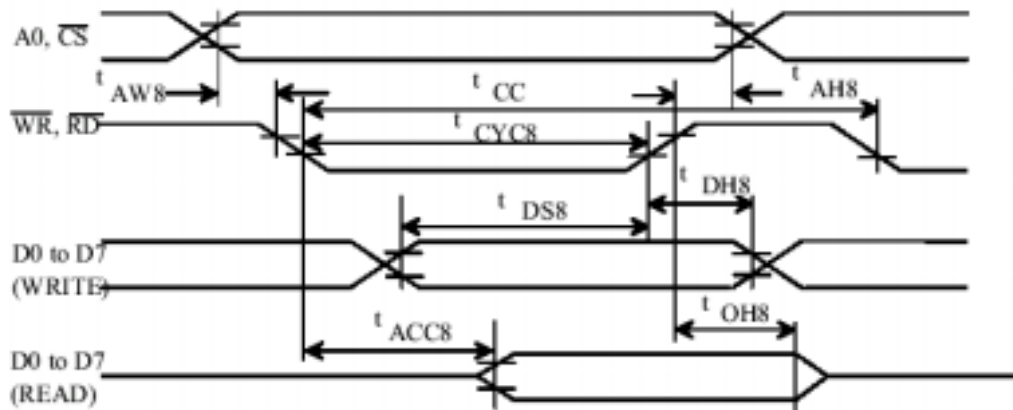

Ta= -20 to 75 deg. C, Vss= -1.0± 10% unless stated otherwise

Parameter	Symbol	Condition	Rating		Unit	Signal
			min	max		
Address hold time	tAH8		10	--	ns	A0, CS
Address setup time	tAW8		20	--	ns	
System cycle time	tCYC8		1,000	--	ns	WR, RD
Control pulsewidth	tcc		200	--	ns	
Data setup time	tDS8		80	--	ns	DO to D7
Data hold time	tDH8		10	--	ns	
RD access time	tACC8	CL= 100pF	--	90	ns	
Output disable time	tCH8		10	60	ns	

Notes : 1. Increase parameter values by 200% when Vss= -3.0V.

2. All inputs must have a rise and fall time of less than 15 ns.

• MPU Bus Read/Write II (68-family MPU)

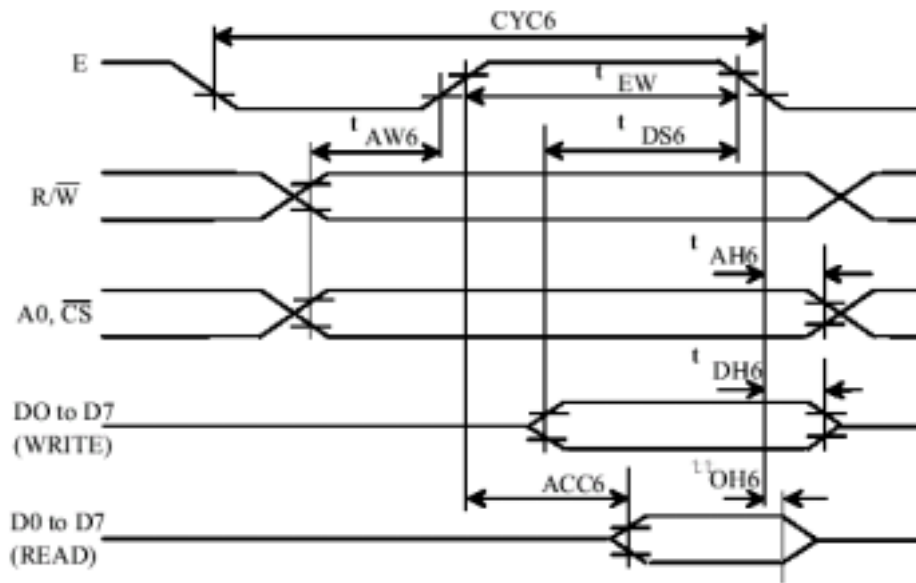

Ta= -20 to 75 deg. C. Vss= -5V ± 10 unless stated otherwise

Parameter	Symbol	Condition	Rating		Unit	Signal
			min	max		
System cycle time	tCYC6		1,000	--	ns	A0, \overline{CS} , R/W
Address setup time	tAW6		20	--	ns	
Address hold time	tAH6		10	--	ns	
Data setup time	tDS6		80	--	ns	D0 to D7
Data hold time	tDH6		10	--	ns	
Output disable time	tOH6		10	60	ns	
Access time	tACC6	CL= 100pF	--	90	ns	
Enable pulsewidth	Read	tEW		100	ns	E
	Write			8	ns	

- Notes : 1. tCYC6 is the cycle time of \overline{CS} . E=H. not the cycle time of E.
 2. Increase parameter values by 200% when Vss= -3.0V.
 3. all inputs must have a rise and fall time of less than 15 ns.

• Display Control Signal Timing

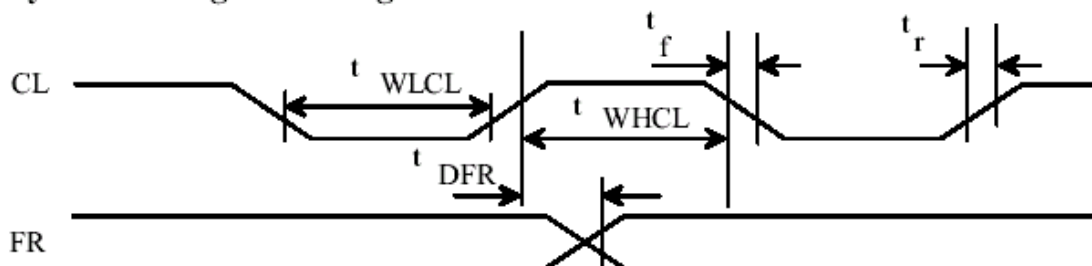

■ SYSTEM BLOCK DIAGRAM

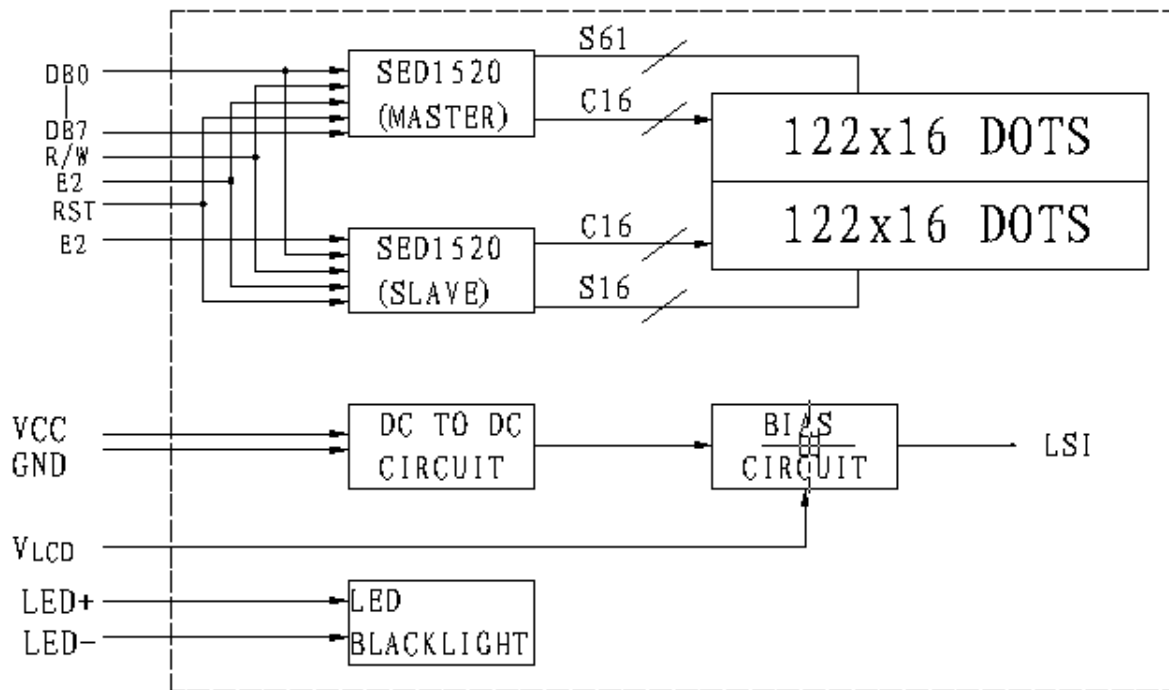

■ ASSEMBLY DIAGRAM

