

---

**Specification**

**For**

**LCD Module**

**LH2020-1**

# LH2020-1

## ■ SCOPE

This specification is applied to the liquid crystal display module ADT-2020/C/S/L\* with 1/16 duty.

\*C: Bonding IC; S: STN LCD; L: LED Back-light

## ■ DISPLAY CONTENTS

2Lines x 20 characters (5 x 8 Dots), 1/16 duty-cycle LCD display

## ■ MECHANICAL CHARACTERISTICS

Item	Description	Unit
Outline Dimension	116.0(L) x 37.0(W) x 11.0/14.0(H)*	mm
Viewing area	83.6(L) x 18.5(W)	mm
Weight	about 40/50	g

\*L: H=14.0mm; 50g

## ■ SYSTEM BLOCK DIAGRAM

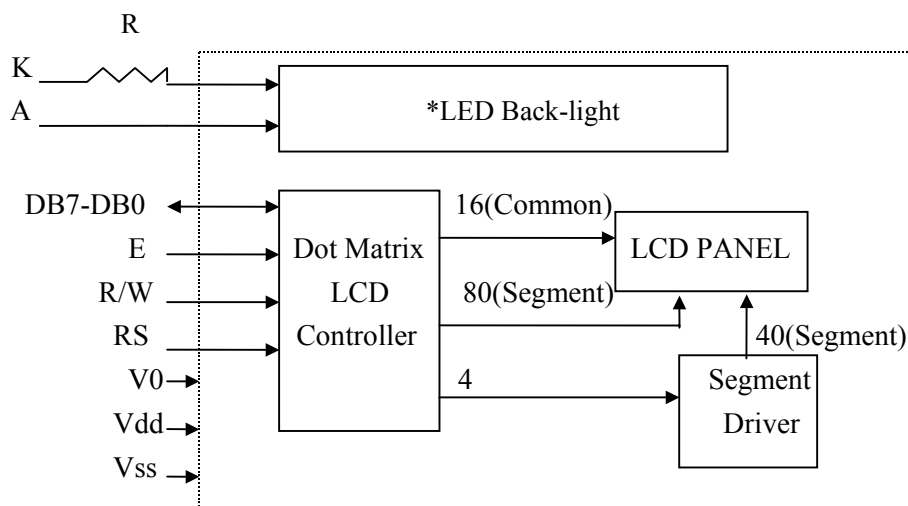

\* Option

## ■ Absolute Maximum Ratings

Item	Symbol	Min.	Max.	Unit
Power Supply for Logic	Vdd	-0.3	+7.0	V
Power supply for LCD Drive	Vlcd	Vdd-11.5	Vdd+0.3	V
Input Voltage	Vi	-0.3	Vdd+0.3	V
Operating Temperature	Ta	0	+50	°C

Storage Temperature	Tstg	-10	+60	°C
---------------------	------	-----	-----	----

■ **Electrical Characteristics**( $T_a=25^{\circ}\text{C}$ ;  $V_{dd}=5.0\text{V} \pm 5\%$ , otherwise specified)

Item	Symbol	Test Condition	Min.	Typ.	Max.	Unit
Power Supply for Logic	Vdd	--	4.5	--	5.5	V
Operating Voltage for LCD	Vdd-Vo	--	--	5.0	--	V
Input "high" voltage	Vih	--	2.2	--	Vdd	V
Input "low" voltage	Vil	--	-0.3	--	0.6	V
Output "high" voltage	Voh	-Ioh=0.2mA	2.4	--	--	V
Output "low" voltage	Vol	Iol=1.2mA	--	--	0.4	V
Power supply current	Idd	Vdd=5.0v	--	2.0	5.0	mA

■ **LED Back-light**(\*Option)

Item	Symbol	Conditions	Rating	Unit
Power Dissipation	Pmax	--	1960	mW
Forward Voltage	Vf	Type	4.4	V
Reverse Voltage	Vrmin	Ir=1400uA	10	V
Average Forward Current	Ifmax	Vf=4.4V	350	mA

■ **PIN ASSIGNMENT**

No.	Symbol	Level	Function	
1	Vss	--	0V	Power Supply
2	Vdd	--	+5V	
3	V0	--	for LCD	
4	RS	H/L	Register Select: H--Data, L--Instruction	
5	R/W	H/L	H--Read L--Write	
6	E	H,H-L	Enable Signal	
7	DB0	H/L	Data bus used in 8 bit transfer	
8	DB1	H/L		
9	DB2	H/L		
10	DB3	H/L		
11	DB4	H/L	Data bus for both 4 and 8 bit transfer	
12	DB5	H/L		
13	DB6	H/L		

14	DB7	H/L	
15	K	--	Led Back-light(-)
16	A	--	Led Back-light(+)

### ■ AC Characteristics and Input Timing Characteristics

AC characteristics (Vdd=5V±10%,Vss=0V Ta=25°C)

Write mode(writing data from Micom to KS0070B)

Characteristic	Symbol	Min.	Typ.	Max.	Unit	Test pin
E cycle time	Tc	500	--	--	ns	E
E rise time	Tr	--	--	25	ns	E
E fall time	Tf	--	--	25	ns	E
E pulse width (High,Low)	Tw	220	--	--	ns	E
R/W and RS set-up time	Tsu1	40	--	--	ns	R/W,RS
R/w and RS hold time	Th1	10	--	--	ns	R/W,RS
Data set-up time	Tsu2	60	--	--	ns	DB0~DB7
Data hold time	Th2	10	--	--	ns	DB0~DB7

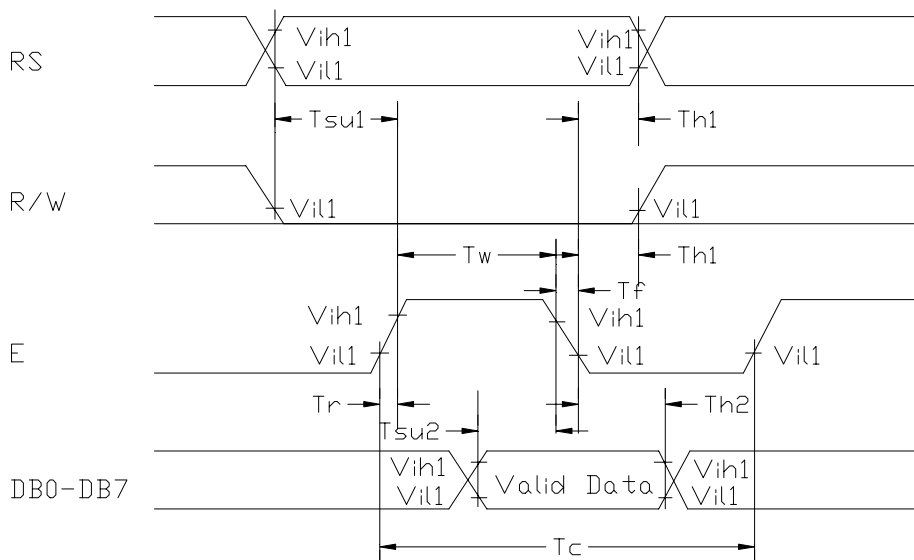

## ■CONTROL and DISPLAY COMMAND

Command	RS	R/W	DB7	DB6	DB5	DB4	DB3	DB2	DB1	DB0	Remark
Display Clear	L	L	L	L	L	L	L	L	L	H	
Return Home	L	L	L	L	L	L	L	L	H	X	cursor move to first digit
Entry Mode Set	L	L	L	L	L	L	L	H	I/D	SH	I/D:set cursor move direction H-Increase L-Decrease SH:Specifies shift of display H-display is shifted L-Display is not shifted
Display On/Off	L	L	L	L	L	L	H	D	C	B	D:Display(H-on,L-off) C:Cursor(H-on,L-off) B:Blinking(H-on,L-off)
Shift	L	L	L	L	L	H	S/C	R/L	X	X	SC:(H-Display shift,L-Cursir move) R/L:(H-Right shift,L-Left shift)
Set Function	L	L	L	L	H	DL	N	F	X	X	DL:(H-8 bits interface,L-4 bits interface) N:(H-2 line display,L-1 line display) F:(H-5 x 10 dots,L-5 x 7 dots)
Set CG RAM Address	L	L	L	H	CG RAM address (corresponds to address)					CG RAM Data is sent and received after this setting	
Set DD RAM Address	L	L	H	DD RAM address					DD RAM Data is sent and received after this setting		
Read Busy Flag & Address	L	H	BF	Address Counter used for Both DD &CG RAM address					BF:(H-Busy ,L-Ready) --Reads BF indication internal operating is being performed --reads address counter contents		
Write Data	H	L	Write Data					Write data into DD or CG RAM			
Read Data	H	H	Read Data					Read data from DD or CGRAM			

## ■ ASSEMBLY DRAWING

●C, CS:

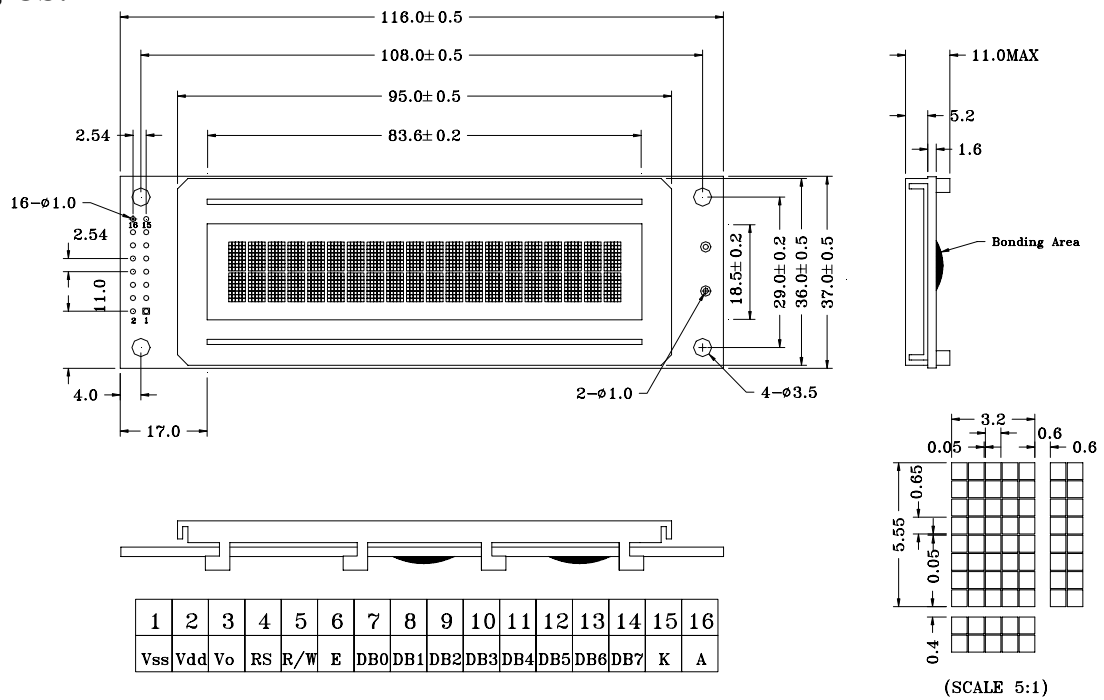

●CL, CSL:

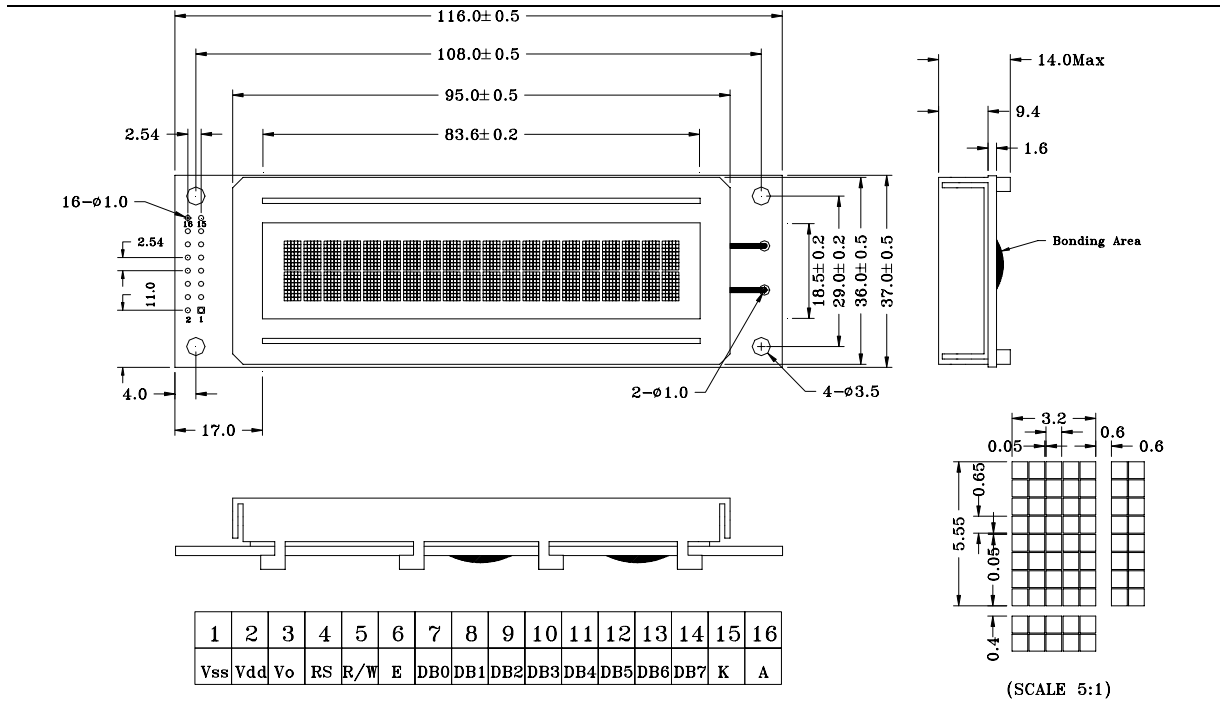

Note: QFP Package IC also available